

Laboratory Experiment 1

Signals & Scope

Peter Cheung
Department of Electrical & Electronic Engineering
Imperial College London

URL: www.ee.ic.ac.uk/pcheung/teaching/signals_scope/
Email: p.cheung@imperial.ac.uk



Welcome to your first Electronics Laboratory Session. You will be spending a lot of time every week in the Laboratory to learn about the practical aspects of electrical and electronic engineering. To make good use of the Laboratory time, you are strongly recommended to read through this instruction document ahead of the laboratory sessions.

The first experiment is about electrical signals and how to measure them using a digital multimeter (DMM) and an oscilloscope. Understanding electrical signals and how to characterise them are fundamental to the rest of the EEE/EIE course. So, work hard on this experiment and have fun.

This instruction takes the form of PowerPoint slides with notes. The slides tell you what to do, and the notes provide further explanations. If you understand what to do from the slides alone, you don't need to read the note page.

In addition to this Experiment Instruction, you can also find various supporting materials on this experiment webpage:

http://www.ee.ic.ac.uk/pcheung/teaching/signals_scope/



The experiment is divided into three phases:

- 1. Learning** – you will be guided through various steps so that you learn how to use the scope to measure and to characterise electrical signals.
- 2. Testing** – you will test yourself by exploring and discovering some unknown electrical signals on the experiment Black Board (BB) provided.
- 3. Evaluation** – you will be evaluated and obtain feedback on how much and to what extent you have attained the desired learning outcomes via a short interview with a GTA (Graduate Teaching Assistant) when you have completed the entire Lab.

A Digital Multimeter (DMM)

- ◆ DMM is a basic electrical measurement equipment.
- ◆ We use a DMM to measure DC or AC voltages.
- ◆ You can also use the DMM to measure resistance of a component.
- ◆ DMM **cannot** tell you much about a time-varying signal.
- ◆ For that you need to use an oscilloscope, or scope for short.

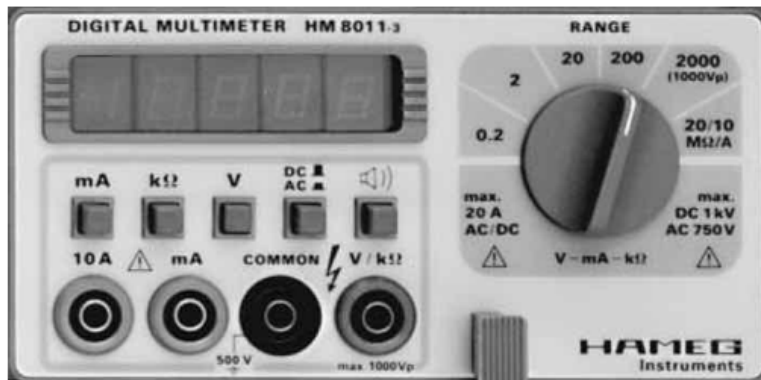

The HAMEG
DMM used in
the Lab

PYKC (v2.1) 6 Oct 2017

EE 1/ EIE 1 Lab –Signals & Scope

Lab 1 Slide 2

Digital Multimeter (DMM) is the most basic equipment you can find to measure electrical signals. You could even buy one in a high street shop for under £10! The ones you will be using in the lab is more sophisticated and accurate than those you use at home. Shown here is one made by HAMEG.

The DMM can tell you the voltage or current of a DC signal (a DC signal source is at a fixed voltage, such as the voltage of a battery). It can measure the root-mean-square (RMS) voltage of an AC signal (such as your mains voltage). For that, the DMM assumes the signal to be sinusoidal. The AC RMS voltage reading \approx amplitude/ $\sqrt{2}$. More on RMS voltages in Mike Brookes' Lecture.

There are four terminals on our DMM. "COMMON" is always used to connect to one end of the a circuit no matter what sort of measurement you are making. It is the reference terminal.

For voltage or resistance measurements, you would use the "V/k Ω " terminal. For current measurements, you would use either the "mA" terminal for measuring low currents or the "10A" terminal for measuring high currents.

For this Lab, we will only be using the "COMMON" and the "V/k Ω " terminals.

You can also use a scope to measure DC voltages, but the accuracy on the scope is inferior to that of a DMM. As you will see later in the experiment, the scope we are using also has a built-in voltage measurement feature.

A DMM that only measures voltages is also called a DVM – a digital voltmeter.

Watch and Learn

- ◆ Before proceeding, watch this video via the QR code.

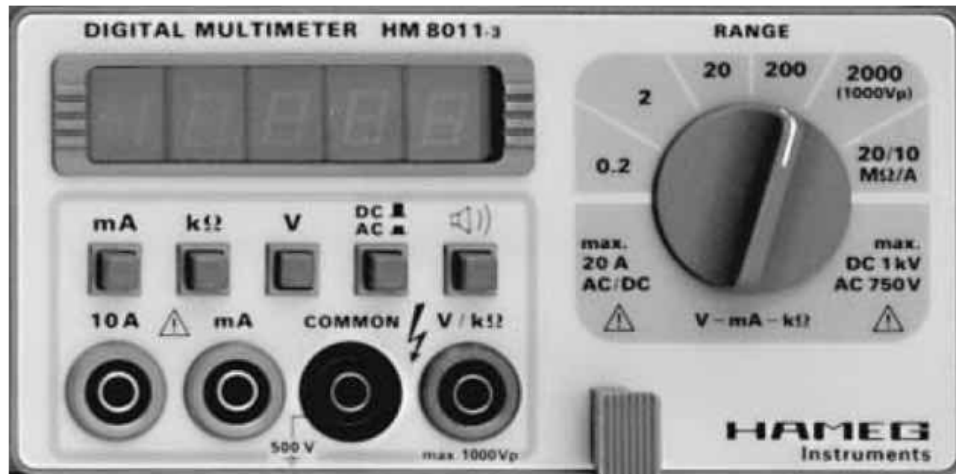

PYKC (v2.1) 6 Oct 2017

EE 1/ EIE 1 Lab –Signals & Scope

Lab 1 Slide 3

Before progressing further, I suggest that you watch the video by Collin Cunningham about the multimeter on YouTube. The link to the video can also be found on the experiment web page.

I also include the QR code for all links. You can use your smart phone with a suitable free app to get to the page directly.

Experiment webpage link:

www.ee.ic.ac.uk/pcheung/teaching/signals_scope/



The YouTube video link:

www.youtube.com/watch?v=BW3Wj7UD-_s&nohtml5=False



What is an oscilloscope for?

- ◆ We use the oscilloscope to measure
 - the presence or absence of a signal that changes over time
 - electrical signals as voltage value vs time
 - the frequency or period of a periodic signal
 - the time gap between two events in the signal (e.g. two consecutive heartbeats)
 - the amount of noise (random signals) on a regular signal
 - the state of a digital signal, i.e. is it a '0' or a '1'?
- ◆ There are two types of scopes: analogue and digital.
- ◆ For this experiment we will be using the Rohde & Schwarz (R&S) HMO 1002 digital scope.



PYKC (v2.1) 6 Oct 2017

EE 1/ EIE 1 Lab –Signals & Scope

Lab 1 Slide 4

A DMM or a DVM (Digital Volt Meter) is useful to measure DC or AC voltage or current of an electrical signal. It cannot give you information about a signal that changes quickly over time. For that you need to use an oscilloscope (or scope for short).

We use a scope to check whether a signal is changing and to see if the signal is repetitive. If it is repetitive, we can measure the signal frequency and peak-to-peak amplitude. If the signal is not repetitive but changing over time, we can also measure the time between two events such as the time between consecutive heartbeats.

We also use the scope to measure the unwanted noise signal on top of the wanted signal.

Although the scope is generally used to measure analogue signals, we can also use it to observe and measure digital signals.

There are different types of scopes. They can be analogue or digital scopes. Modern scopes are generally digital. We are using one of the latest digital scopes, the HMO 1002, in this experiment.

You can find the HMO 1002 User's Manual of the scope on the Experiment webpage and links to lots of different YouTube videos on how to

Link to Experiment webpage:

www.ee.ic.ac.uk/pcheung/teaching/signals_scope/



Link to User's Manual:

www.ee.ic.ac.uk/pcheung/teaching/signals_scope/HMO1002.pdf



What will you learn in this Experiment?

- ◆ By the end of this experiment (lasting up to 10 hours over 4 separate time slots), you will have learned:
 - What would you use an oscilloscope for?
 - How do you adjust the vertical control to measure voltage levels?
 - How do you adjust the horizontal control to measure time period?
 - How do you adjust the trigger control to obtain a stable waveform display?
 - What are the differences between AC and DC measurements?
 - How do you use the oscilloscope to characterise electrical signals?
 - What are the different types and forms of common electrical signals?
 - How do you describe quantitatively these common forms of electrical signals?
 - How do you use an oscilloscope to measure digital signals?
 - What do you use a high impedance probe and why is it needed?
 - How do you use a signal generator to produce arbitrary, repetitive waveforms?
 - How do you use a scope to interpret digital signals that convey information such as text characters (in a special code called ASCII)?

This is a list of the learning outcomes expect of you from this experiment. It is useful to come back to this slide later and ask yourself: “How much have I managed to master in this list of learning outcomes?”

In the next part of the experiment, you will be guided through detail instructions in order to measure known signals. You will learn what the different knobs and buttons on the scope are for. You will learn how to get a stable signal on the screen of the scope. This is called “**triggering**” the scope. You will learn about accuracy and precision (or lack of these) of the scope as a measurement instrument.

In a second part of the experiment, you are required to measure, record and describe a number of unknown signals produced by the experiment Black Board (BB). The goal of the second part is to help you gain confidence in your ability to operate the scope in order to measure and characterise electrical signals.

One final point, I have written this experiment in order to encourage **DISCOVERY**. I deliberately do not give you step by step instructions and lead you “by the nose”. Instead, you are told about the objective of each of the task or test that you will be doing. I intend for you to find things out for yourself where possible. **ONLY ASK A GTA** if you really have to. Trust me, you will learn a lot more this way and it will also be much more FUN.

Logbook

- ◆ You MUST keep a record of your practical work using either a paper or, preferably, an electronic “**logbook**”.
- ◆ Here are some guidelines on using the logbook:
 - For all engineers, it is desirable to develop a habit of keeping good log of what you have done.
 - Logbook should include sketches, your thoughts etc., and **does not need to be tidy**. It definitely should not be “beautiful”.
 - **Never** copy someone else’s logbook – it is both cheating and useless to you.
 - Include photo’s, plots, prints or anything else of interest in your logbook. This is where electronic logbook is most useful.
 - During the lab oral assessment, you will be asked questions where **answers can only be found in your logbook**.
- ◆ This is what you should write in your logbook:
 - what you plan to do
 - what results were obtained
 - how they were obtained
 - your thoughts about the results
 - **reflections** on what you have learned
- ◆ You can find a useful guide on using electronics logbook here:
www.ee.ic.ac.uk/pcheung/teaching/signals_scope/elogbook.pdf



At this early stage of your study at Imperial, we want to get you into a habit of WRITING THINGS DOWN. It is amazing how spending a few minutes to write down what you have done would help you digest the materials. It also forces you to question if you have really understood your actions and the significance of the results from the experiment.

Your logbook for this experiment will not be explicitly marked. ALSO REMEMBER, the purpose of you being here is to LEARN. **Getting good grades should be the consequence of good learning.** Good marks should always be the consequence of you attending university and not the goal!

Some students write their logbooks in the evening, or even at the end of the experiment. THIS IS VERY INEFFICIENT AND DEFEATS THE PURPOSE OF KEEPING A LOGBOOK.

You should cultivate the habit and the culture of “**do it once, do it well, and do it now**”.

Finally, I also want you to learn to use an electronic logbook. It is a very useful tool for many other things you will be doing while being a student at Imperial College.

I have written a useful guide for those who don’t know much about how to use an electronic logbook here:

http://www.ee.ic.ac.uk/pcheung/teaching/signals_scope/elogbook.pdf



Basic layout of the front panel

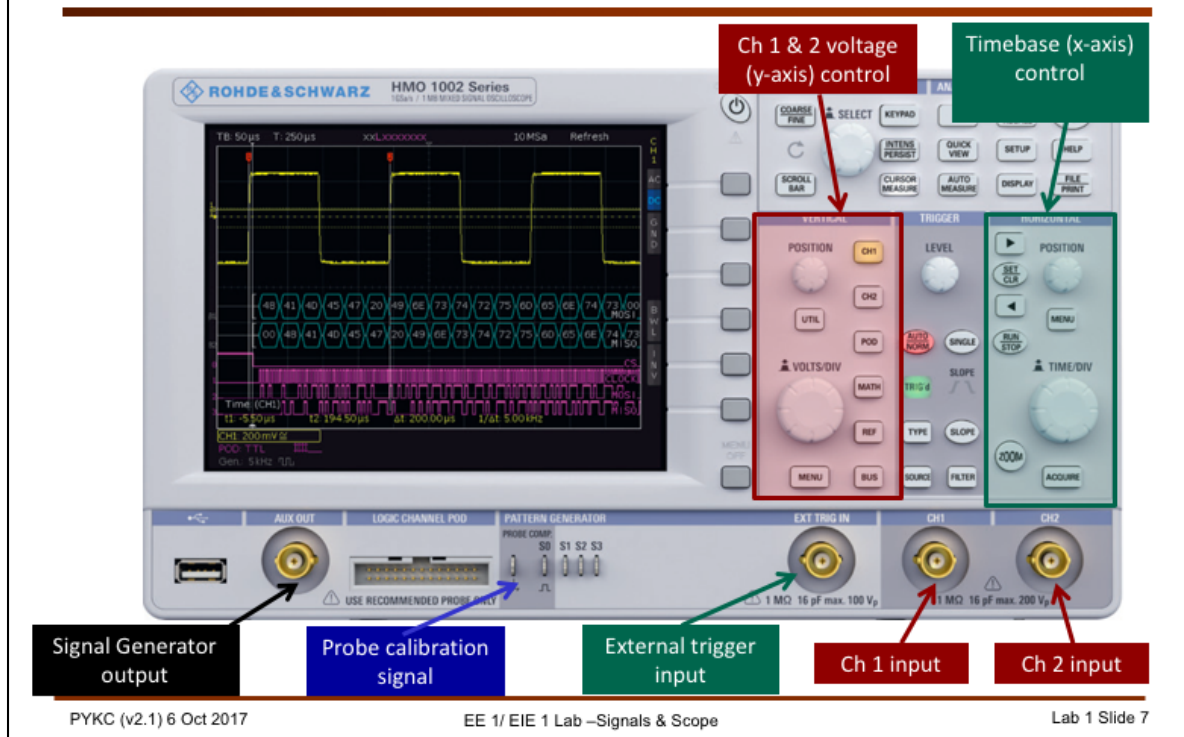

The layout of the scope is divided into different regions (or panels). The two main panels are: 1) VERTICAL control for Channel 1 and channel 2; 2) HORIZONTAL control for time or x-axis. The vertical control determines the voltage scale in volts/division and the position of the zero voltage reference. The horizontal control determines the time scale in sec/division relative to a time reference determined by something called the “trigger”.

The middle groups of knobs and buttons are the **trigger controls**. Trigger is the mechanism that determines when the scope should start a display plotting from left to right (i.e. the time origin of the waveform). Since this is a digital scope, we can display what happens BEFORE time zero (i.e. the trigger point).

There are various trigger modes. Two are most common:

Auto – means the scope will do its best to automatically trigger the display scan, no matter if the trigger condition is met or not. It is the most useful setting. This may result in a “moving” display.

Normal – means the scope will only start a display scan if the trigger condition is satisfied. Under this mode, the display is usually stationary or blank. This is useful to capture rarely occurring events.

There are also various trigger sources: CH 1, CH 2 and EXT are most commonly used.



Watch and Learn

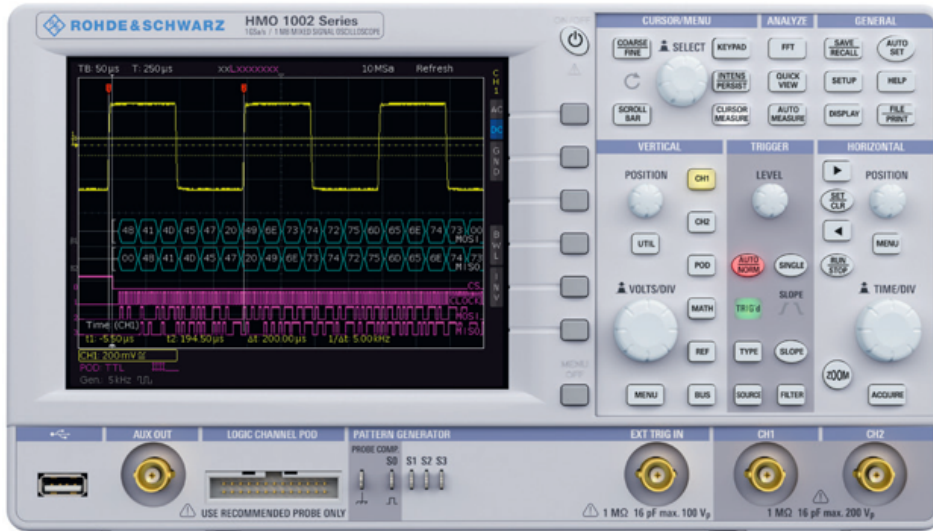

PYKC (v2.1) 6 Oct 2017

EE 1/ EIE 1 Lab –Signals & Scope

Lab 1 Slide 8

Now before progressing further, I suggest that you watch the video by Collin Cunningham about the oscilloscope on YouTube:

https://www.youtube.com/watch?v=SxZWcku_Sw0



Now watch the video explaining what is and how to trigger an oscilloscope in order to get a steady waveform display via the link below. **IT IS IMPORTANT FOR YOU TO UNDERSTAND THE CONCEPT OF TRIGGERING ON A SCOPE.**

<https://www.youtube.com/watch?v=H0Czb2zBzsQ>



Task 1: Measure a 1.1kHz sine wave

- ◆ Use the HAMEG function generator to produce a sine wave at 1.1kHz and a peak-to-peak amplitude of 2V, and centred around 0V (i.e. zero offset).
- ◆ Connect the scope CH1 input to the signal output using a BNC-to-BNC cable.
- ◆ Measure the signal with the scope to confirm the pk-pk amplitude, frequency and offset values.
- ◆ Use the DMM to measure the voltage sine wave.

- Explain the DMM reading.
- How precisely can you measure the amplitude using the scope and using the DMM? Justify your answer.



PYKC (v2.1) 6 Oct 2017

EE 1/ EIE 1 Lab –Signals & Scope

Lab 1 Slide 9

Task 1 : You are required to generate a 1.1kHz sine wave signal with 2V pk-to-pk amplitude and centred at zero volt. That is, the dc offset is 0. You do this with the bench-top HAMEG function generator (for now). Connect the function generator output to both the scope CH1 and the DMM input using suitable cables and adaptor.

The function generator is easy to use. You can set the frequency precisely. Setting the amplitude and offset is less precise. Connect the function generator to the scope with a BNC to BNC cable.

Now adjust the scope for the appropriate vertical (V/div) and horizontal (sec/div). Set the trigger control as: AUTO, SOURCE = CH1.

You may need to adjust the trigger-level knob in order to get a steady waveform. (Make sure you understand the idea of trigger.)

Adjust the amplitude knob on the function generator for a 2V pk-pk amplitude, and adjust the offset knob for zero offset.

Now measure the output signal level with a DMM using AC setting, and explain the measured value.

Finally, think about how precisely you will be able to measure the amplitude using the scope and the DMM.

Play around with all the control knobs and buttons circled in RED, and learn what they do.



Task 2: Using the Scope's signal generator

- ◆ We will now use the built-in function generator of the scope to produce the 2V pk-pk amplitude sine wave. Connect the AUX OUT signal on the left of the scope to the input of CH1 using the BNC cable.
- ◆ Press the **UTIL** button on the VERTICAL panel, and select FUNCTION GEN on the on-screen menu.
- ◆ You can now set the desired signal type (sine), frequency (1.1kHz) and pk-pk amplitude (2Vpp). Measure this on the scope.
- ◆ Next, generate a 100mV pk-to-pk sinewave on a 2.8V offset at 1.1kHz using the scope's function generator.
- ◆ Measure this using the scope as before. You should see a waveform similar to the one below.
- ◆ Produce a hardcopy of the screen by plugging in a USB drive to the scope (far left) and press the **FILE PRINT** button. This allows you to copy and paste the screenshot in your logbook.

Task 2 : The HMO 1002 is much more than just a digital oscilloscope. It also includes a function generator which can produce different types of signals up to 50kHz, and a measurement system to measure voltages and frequencies. In many ways, using the built-in signal generator of the digital scope is easier than using the HAMEG function generator. However, the HAMEG can produce a much higher frequency signal than the scope.

Follow the instruction as above to generate first a 2Vpp sinewave with zero offset at 1.1kHz. Make sure that you get the same measurement on the scope.

Then change this to a 100mVpp sinewave with a 2.8V offset. You should see a waveform something like the one shown below:

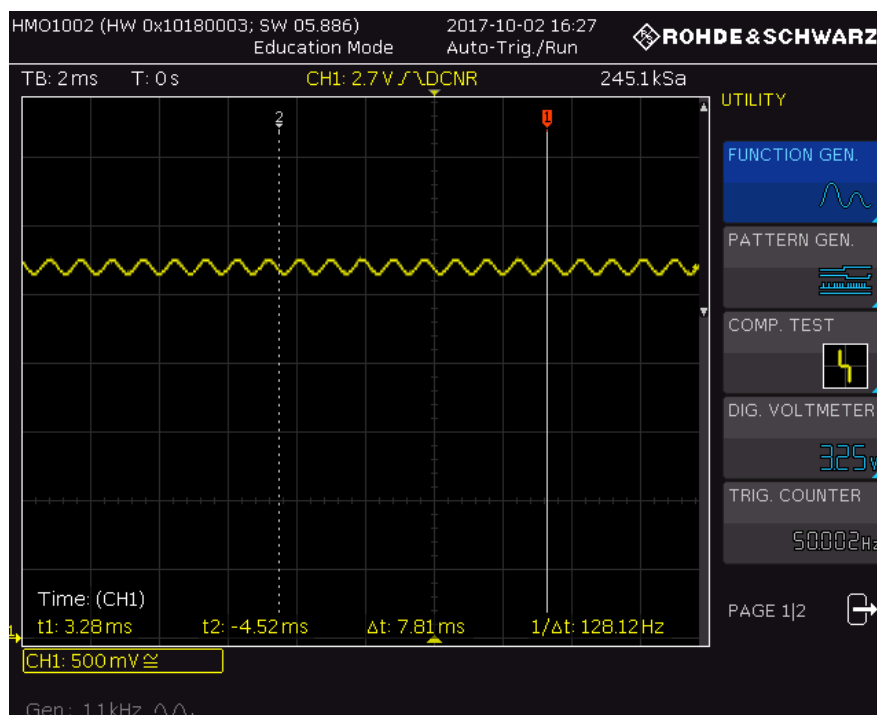

On-screen menu

Task 3: DC and AC coupling

- ◆ In task 2, we measured a small time-varying (AC) signal superimposed on a large DC offset. The scope was in DC coupling setting. It showed both the DC offset and the AC signal on the same screen. The AC measurement was inaccurate.
- ◆ To measure the AC component of the signal accurately, we need to use AC coupling.
- ◆ Select CH1, and then press the AC-DC on-screen menu button to select AC coupling.

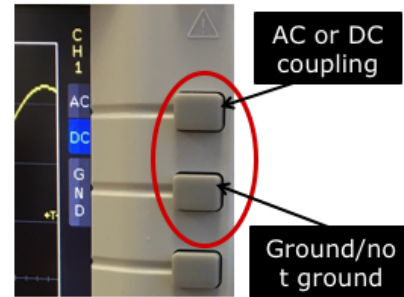

- ◆ Enlarge the tiny sine signal to fill the entire screen.
- ◆ Here is something worth remembering - Measuring a small time-varying signal sitting on a large DC offset requires two steps:
 1. Use DC coupling to measure the offset level;
 2. Use AC coupling to measure the peak-to-peak amplitude.

PYKC (v2.1) 6 Oct 2017

EE 1/ EIE 1 Lab –Signals & Scope

Lab 1 Slide 11

Task 3: This task aims to teach you how to use the scope channel (CH1) in two type of settings: AC and DC. So far, you have been only using DC setting (also called DC coupling). You will not understand exactly what this means until you have had a few lectures by Mike Brookes only “circuit analysis”. Essentially, DC coupling simply means a direct connection between the signal and the scope input circuit. Under this setting, everything is passed through and measured.

Unfortunately if you measure a tiny AC signal sitting on a large DC signal, the DC offset (in this case, the 2.8V DC) swarms the AC signal. You see a small wiggling waveform on the screen. Changing the Y-axis (or voltage) scale knob will not help you. This amplifies both DC and AC signal, and the entire waveform goes off-screen!

The solution is to put the Channel into AC coupling mode.. Under this mode, the signal is passed through a capacitor before reaching the scope input circuitry. You will learn later in the course that the capacitor has the property of BLOCKING the DC signal, and only allows the AC part of the signal to go through. That’s why it is called “AC coupling”.

If you use the AC coupling setting, you can amplify the signal with the voltage scaling knob and measure the peak-to-peak amplitude properly.

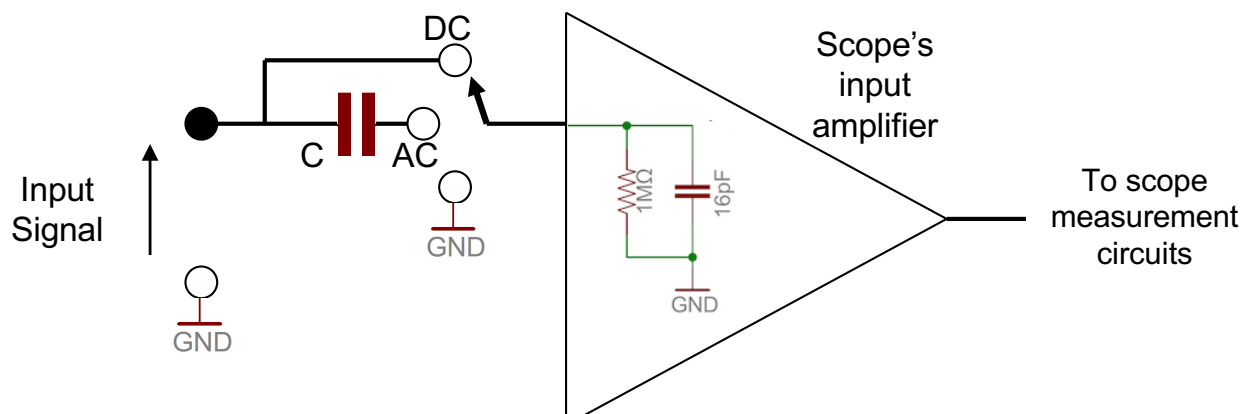

Task 4: Trigger and cursor measurements

- ◆ Before starting this task, make sure that you understand the video on scope trigger in Slide 8.
- ◆ In this task, you will learn more about the trigger mechanism and how to use cursors to make measurements.
- ◆ Use the signal in Task 3 and set the scope to: AC coupling, CH1. Adjust the TRIGGER LEVEL knob until the cross-hair symbol is right at the centre of the screen.
- ◆ The cross-hair shows the time and voltage when trigger occurs. Now change the slope of trigger between rising, falling and both. Explain what you see.

- ◆ Finally, press the **CURSOR MEASURE** button, and explore how to adjust the cursor position to measure both time and voltage values on the waveform yourself.



PYKC (v2.1) 6 Oct 2017

EE 1/ EIE 1 Lab –Signals & Scope

Lab 1 Slide 12

Task 4: This task is about trigger control and the use of cursors to take measurements on the waveform. When you turn the LEVEL knob on the TRIGGER panel, you tell the scope to start the display scan at different voltage level of the CH1 signal. It is very important that you understand exactly what “triggering” means when using a scope. This is one of the important learning outcomes of this Lab Experiment.

Once the scope is triggered, you will see a steady waveform on the scope display. You can then use the CURSOR feature to move around and

You can also choose to trigger on the rising or falling edge, or both.

Another useful feature on this scope is the use of **CURSOR MEASURE**. This brings up the various cursors for measuring times and voltages.

To use the cursor to measure time:

1. Press the CURSOR button.
2. Select MEASURE TYPE = time with the on-screen menu.
3. Press the SELECT knob to select the cursor.
4. Turn the knob to adjust the cursor position.
5. Press the knob again to change which cursor to adjust.

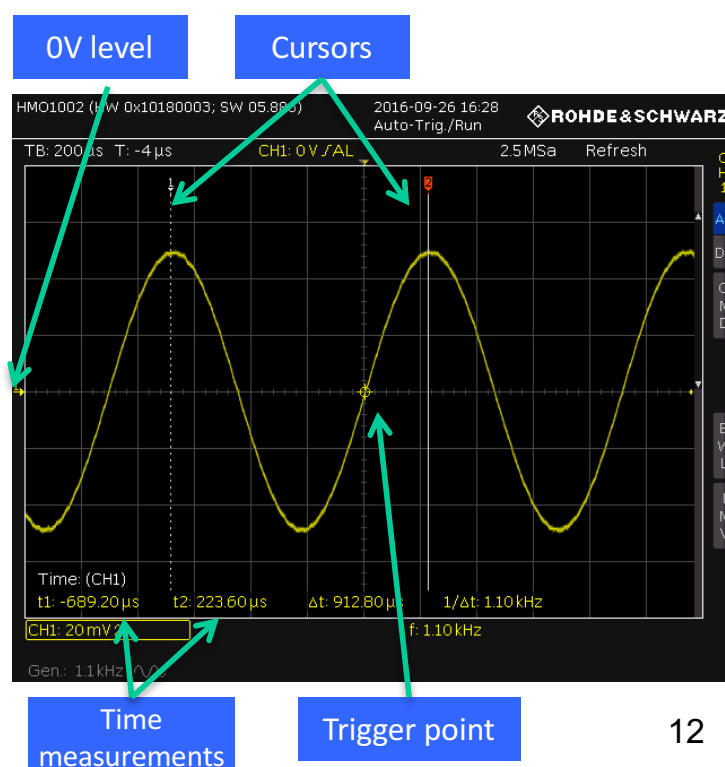

Task 5A: Measuring digital signals

- ◆ Use the pulse option of the scope's function generator to produce a 3.3V digital signal at 8kHz with equal mark-space ratio. (That is, '0' at 0v and '1' at 3.3V with equal high and low periods.)
- ◆ You can accomplish this by: 1) select PULSE signal, 2) set amplitude to 3.3V, 3) set offset voltage to 1.65V, 4) set duty cycle to 50%.
- ◆ Measure the signal with CH 1 of the scope to confirm the high and low logic voltage level, the frequency and the duty cycle.
- ◆ Use the CURSORS option to measure rise and fall times (i.e. t_r and t_f). This is the time it takes for the signal to go from 10% to 90% of full scale (and vice versa).

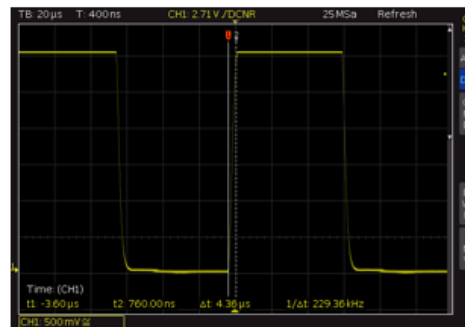

PYKC (v2.1) 6 Oct 2017

EE 1/ EIE 1 Lab –Signals & Scope

Lab 1 Slide 13

Task 5: This task is to produce and to measure a digital signal at 8kHz and using 3.3V low voltage (LV) logic levels.

TTL levels: Traditional digital circuits use 5V TTL voltage levels. Most modern microprocessors however use lower voltages where '0' is around 0v and '1' can be between 1.1V to 3.3V.

3.3V LV levels: With 3.3V digital logic, '0' is approximately 0v and '1' is approximately 3.3V. (LV is for low voltage.)

You are required to produce a LV digital signal at 8kHz. This signal could be used to drive digital logic circuit that complies with the 3.3V LV standard.

In digital logic, you often find logic signals that are symmetrical, i.e. equal high and low periods. The ratio between the time the signal is high (t_H) (i.e. the pulse width) to the period of the waveform (t_C) is known as **duty cycle**. So, a symmetrical clock signal has a 50% duty cycle.

$$\text{duty cycle} = \frac{\text{time when signal is high } (t_H)}{\text{period of the signal } (t_C)} \times 100\%$$

Task 6: Using the x10 probes (1)

- ◆ Using BNC cable to do measurement on signals at high frequencies will result in signal attenuation and/or signal distortion.
- ◆ We almost ALWAYS use a scope with its dedicated measurement probes, known as the **high impedance** or **x10 probe**.
- ◆ There is a x1 or x10 selector. x1 setting is equivalent to what we have done so far, and is only good for low frequency measurements.
- ◆ **Always** use x10 setting to measure high frequency signals or signals with high source impedance.
- ◆ When you use x10 setting, all readings will be **reduced** by a factor of 10.

- ◆ You must also tell the scope that you are on the x10 setting by:
 - Choose channel CH1 or CH2
 - Press the  button
 - Select on-screen menu PROBE on page 2
 - Select x10

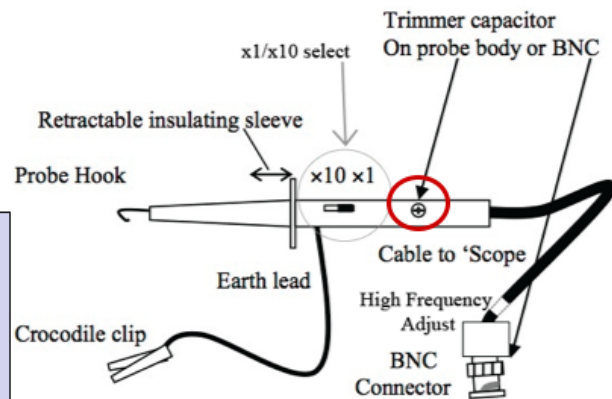

PYKC (v2.1) 6 Oct 2017

EE 1/ EIE 1 Lab –Signals & Scope

Lab 1 Slide 14

Task 6: So far you have been using a BNC cable to do your measurements. From now on, you will ALWAYS use the special probe supplied with the scope. Connect the YELLOW probe to CH 1 and the BLUE probe to CH 2. This will match the colour of the traces on the screen of the scope.

This is known as the “**high impedance probe**” or x10 probe. I need this probe because when the scope is connected to an electrical circuit, it may alter the circuit that it is measuring depending on the scope’s “input impedance” as compared to the circuit impedance. This is called “loading effect” and is something that will be covered in the circuit analysis module later by Mike Brookes.

The scope probe on the x10 setting presents itself with 10 times higher impedance than on the x1 setting. However, the signal it measures is also reduced (attenuated) by a factor of 10. (So strictly speaking, the x10 probe should be more accurately called a divide-by-10 probe, but x10 is the conventional name!)

If you have selected the x10 probe setting, you must also tell the scope that all signals are now reduced by a factor of 10. This you do by selecting the channel (CH1 or CH2), select MENU button and navigate to the PROBE menu and select x10.

In practice, you almost always use the x10 probe setting. So you only need to set up the scope to know the x10 setting once.

Task 6: Using the scope probe (2)

- ◆ Connect both probes to the PROBE COMP hooks as shown below.
- ◆ Before using a scope probe, you need to first "compensate" it by:
 - Make sure that the x1/x10 selector on both probes are on x10
 - Press SETUP button on the GENERAL panel
 - Press PROBE ADJUST button on the on-screen menu
 - Select CH1 or CH2 to set up the probe
- ◆ You will see an on-screen instruction displayed. Read the notes below to learn how to use the special trimmer tool to adjust the trimmer capacitor on the probe until clean edges on the square wave is obtained.



PYKC (v2.1) 6 Oct 2017

EE 1/ EIE 1 Lab –Signals & Scope

Lab 1 Slide 15

Task 6 (continue): Before you can use the x10 probe, you need to calibrate it (also called compensation). This is done by hooking the probe to the compensate output as circled here which is on the scope's panel. Press SETUP and PROBE ADJUST. An on-screen guide will appear. Select CH1 to adjust.

You will see a 1kHz square wave signal. Now use a special trimming tool (non-metallic) to adjust the trimming capacitor on the probe until you get as shape a square wave with a nice looking edges as shown here:

You should ONLY adjust the yellow plastic screw on the black probe. DO NOT TOUCH the adjustments on the BNC connector. (See picture below).

Do the same for CH2.

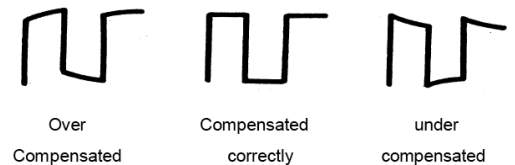

How the high impedance x10 probe works will be covered in the lecture on RC network and transient behaviour. The internal circuit looks something like this. You don't need to understand this for now.

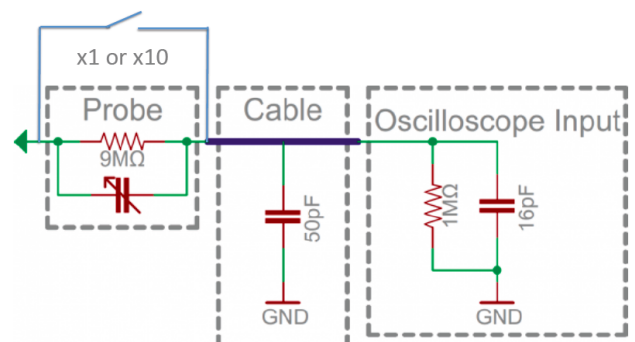
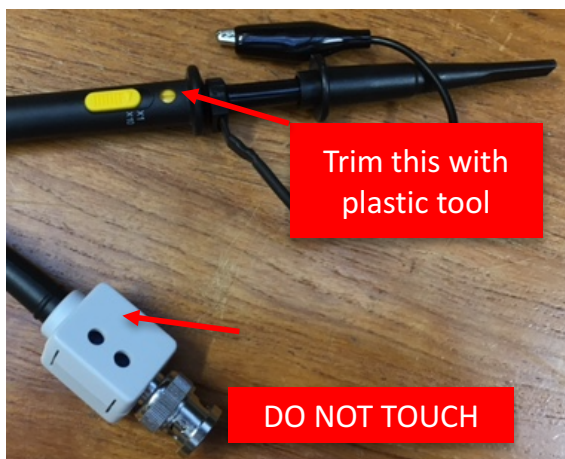

Task 6: Using the scope probe (3)

- ◆ Now let us examine why we should use the x10 probe to measure fast edges (or high frequency signals).
- ◆ Exit the PROBE ADJUST mode and return to the normal operating condition.
- ◆ With both probes still clipped on the adjust signal hooks, return CH2 probe to the x1 setting. Turn up the time base (horizontal scale) to show details of the rise transition on both channels.
- ◆ Measure the rise times of the signal on both CH1 and CH2. (Remember rise time is the time it takes to go from 10% to 90% of a transition.)

➤ Comment on your findings.

Task 6 (continue): Finally, I want to show you the difference between using and NOT using the x10 probe in measuring fast edges.

Exit the PROBE ADJUST mode by pressing the EXIT on-screen button. Leave both probes on the PROBE COMP hooks as before.

Now select x1 on the probe of CH2 and leave the probe on CH1 on x10 setting. Set trigger on CH1 and rising edge.

Adjust both the VOLTS/DIV and timebase controls until you see the rising edge on both CH1 (yellow trace) and CH2 (blue trace) clearly.

It is clear that with the x10 probe, the signal reaches the high voltage value much faster than that with the x1 probe. Therefore when measuring a signal with fast edges (fast edges also implies high frequency – something you will learn later in lectures), you need to use the x10 probe. Since the x10 probe also works for slow edges, there is no reason NOT to use it all the time (except when you are measuring very small and low frequency signals).

The Black Board

- ◆ Before you move to the next task, you need to connect the "Black Board" (BB) to the +5V power supply on the bench.
- ◆ The BB consists of a double-deck printed circuit board which generates various test signals, and a breadboard area which you will not use for this experiment. You use the slide switches to select which signal to generate.
- ◆ Different waveforms are produced on the various colour coded test pins as indicated by the four colour LEDs. For example, when a BLUE LED is lit, measure the signal on the BLUE test pin (TP3).

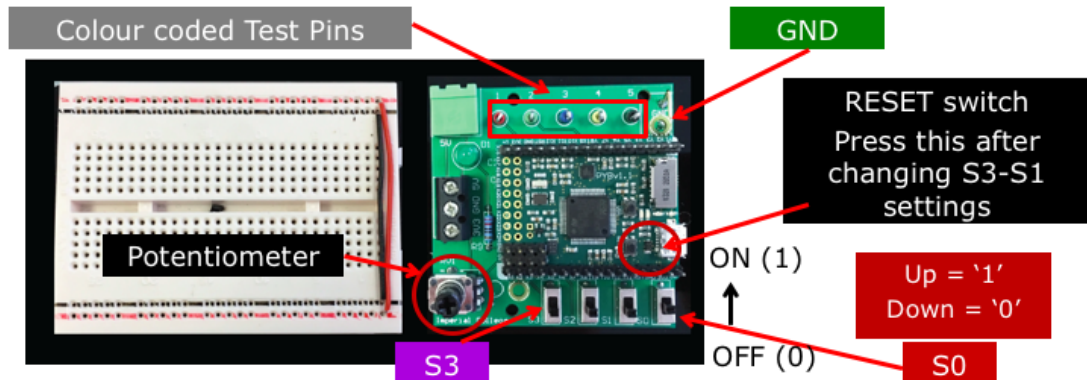

PYKC (v2.1) 6 Oct 2017

EE 1/ EIE 1 Lab –Signals & Scope

Lab 1 Slide 17

The Black Box (BB) is designed to produce various electrical signals for you to measure. These signals are commonly found in electronic systems.

BB is powered by a 5V bench power supply. The BB consists of a bottom printed circuit board (PCB) with board plugged in on top. The top board is known as the Pyboard and it consists of an ARM microcontroller, similar to the processor found on your mobile phone. You don't need to know how this works for this experiment.

What signal is generated is governed by the switch setting (S3 to S0). You dial in a switch setting to select the appropriate waveform generated. The switch is in '1' setting if it is UP.

After the switch setting is changed, you must press the RESET switch as shown above in order of the change to take effect.

Signals are generated on one or more of the colour test pins TP1 to TP5 at the top of the PCB. Measurements are made by hooking your scope probe to these test pins. If a signal is generator, say, on the BLUE pin, a BLUE LED will light up. You also MUST connect the EARTH wire of the probe (crocodile clip) to the GND terminal at the top right corner as shown above.

The breadboard area on the left is not used for this experiment.

Task 7: Exponential signals

- ◆ Set the slide switches to binary 1111 (all ON) or value 0xF (in hexadecimal), and connect CH 1 of the scope to TP3 (BLUE). Press the RESET switch on the PCB (see diagram on last slide) for the switch setting to take effect.
- ◆ You will see the BLUE LED lid up, indicating that the signal is on the BLUE test pin.
- ◆ Select CH1 as trigger source.
- ◆ You should see a square wave signal at 125Hz with an exponential rise and decay characteristic.
- ◆ The low to high transition of the waveform can be described by the equation:
$$V_{out} = V_{pk}(1 - e^{-t/\tau})$$
- ◆ The high to low portion of the waveform can be described by the equation:
$$V_{out} = V_{pk}(e^{-t/\tau})$$

- Use the scope to measure V_{pk} , the signal frequency and the time constant τ .
- Confirm that τ (time constant) $\approx 0.5\text{ms}$. What is the difference between τ and t_r (rise time) of a signal?

Task 7: Set all the switches to the ON position (UP). This is equivalent to a switch setting of 15 or hexadecimal 0xF on the Black Board. Press the RESET switch.

Connect TP3 (BLUE) to CH 1.

You should see a square wave at around 125Hz. However, the rise transition of the waveform follows an exponential function given by the equation:

$$V_{out} = V_{pk}(1 - e^{-t/\tau})$$

Here the reference for t is measured from the time the signal starts to rise from 0V. τ is called the **time constant**. This quantity τ is an important characteristic of the signal. It is the time required for the signal to reach **63.2%** of the final amplitude value, i.e. when $t = \tau$,

$$\frac{V_{out}}{V_{pk}} = (1 - e^{-\tau/\tau}) = 0.632$$

The equation for the falling part of the waveform is (again $t=0$ is the time at beginning of the fall):

$$V_{out} = V_{pk}(e^{-t/\tau})$$

Task 8: Measuring complex digital signal

- ◆ Set the switches to 1110 (or value 0xE) and press RESET.
- ◆ connect the scope to:
 - CH 1 to TP3 (Blue)
 - CH 2 to TP4 (Yellow)
- ◆ Set trigger on CH_1. You should see a sequence of digital pulses on CH 1, and a complex digital signal on CH 2.
- ◆ CH 2 signal is a UART waveform for the ASCII character '#' (hash character with ASCII code of 0x23). Read the notes below for details.

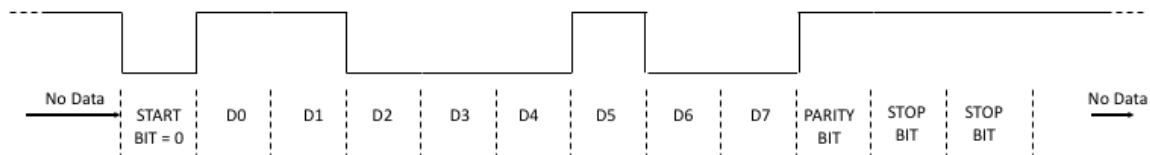

- Record the waveform you see on CH1 and CH2, and explain all the high and low values.

Task 8: Set the switches to '1110'. Connect TP3 (Blue) to CH 1, and TP4 (Yellow) to CH 2. Select CH 1 as the trigger source, rising edge.

What you should see is the ASCII character '#' (hex = 0x23) repeatedly generated once every 7ms as shown above. The communication format is called "UART", **U**niversal **A**synchronous **R**eceiver **T**ransmitter. The data bit rate (also called baudrate) is 9600. Therefore every bit of the data lasts for $1/9600 = 104 \mu\text{s}$.

UART has a specific data bit sequence. When there is no data, the logic level is '1'. When a character is sent, the first data bit period is 0. This is known as the START BIT (always '0'). It is then followed by 8 bits of data, least significant bit first. Then there could be an optional parity bit P. One could use even, odd or no parity bit. If no parity is used, the P bit is missed out. If you use odd parity, the number of ones including the data and parity bits is an odd number. For even parity, the total number of ones is an even number.

We are using EVEN parity here. Since the ASCII code of the letter '#' is hexadecimal 0x23, and there are three '1's in 0x23, therefore the parity bit is therefore '1' in order to make the total number of 1's an even number.

Finally it is guaranteed to have 1 or 2 bit period of high value. This is known as STOP BITS. We use 2 stop bits here.

Explore the UART waveform and make sure that you know how to interpret this digital data format.

Test Yourself with the Black Board

- ◆ For this part of the experiment, you have to set the switch to values ranging from 1 to 9 with S0 to S3 on the Black Board. Do this by converting the value you want into 4-bit binary number. Then adjust the slide switches with UP = '1'.
- ◆ Press RESET to change the BB generated waveform.
- ◆ Remember that measurements should be made on the appropriate test points according to which LEDs are lit.
- ◆ For all signals, you should do the following:

➤ Sketch (or capture the screen image) and describe the signal you measured in terms of:

- Repetitive period or frequency
- Amplitude and shape
- Parameters of interest relating to each waveform
- Where relevant, a mathematical equation of the waveforms

This part of the experiment is designed for you to test how much you have learned. Each BB will provide a set of signals unique to the box. There are 8 different signals coming out the various test pins. Your job is to discover what these signals are, and then to characterise them.

I also want you to check that you have got it right. To do that, you should:

1. Find the “magic number” for your Black Board by setting the switches to zero ('0000'), press RESET, and read the magic number on the board's colour LEDs. The four LEDs are: RED-GREEN-YELLOW-BLUE, with RED being the most significant bit and BLUE the least significant bit. For example, if your BB only have YELLOW and BLUE lighting up, your board's magic number is 3 ('0011').
2. Go to the experiment website and check the solutions table for the expected answer for the test.

TEST 1 – Switch = 1

- ◆ Connect CH 1 to TP3 (Blue).
- ◆ This should be straight forward to discover.
- ◆ However, you should also zoom-in on the x and y axes to a small part of the waveform. What do you see? Record and explain your observations.

I am sure you will have no problem recognising this waveform. Measure its peak to peak voltage and its periodicity as frequency or period.

Now turn up the sensitivity (i.e. volts/div) for y, and the timebase for x, move the waveform to the middle of the scope display. You should see something interesting. Try to explain this yourself. Seek help if you need to.

Note that when you are using high sensitivity (i.e. when the VOLTS/DIV setting is at the lowest setting), the actual signal will appear somewhat noisy, and it has distinct steps in the x and y axes. This is because we are generating an analogue signal using a digital microprocessor.

Firstly, the digital circuit produces lots of noise, which get added onto the analogue signal. To get a clearer signal, you can set the scope to “bandwidth limit”, by pressing the on-screen button BWL. This will get rid of the noise on the display (although the noise is still there on the signal, but the scope will not display it).

Secondly, the steps in time and voltage are due to the way we produce our signal using distinct time step (we call this the sampling period) and distinct voltage step (we call this the quantization step). Measure both.

TEST 2 – Switch = 2

- ◆ Connect CH 1 to TP3 (Blue) and CH 2 to TP4 (Yellow).
- ◆ You should set trigger source to CH1
- ◆ You are measuring a digital signal. Characterise it in terms of signal levels, pattern and periodicity.

This is a simple test and the signal produced are two digital signals. You need to work out what they are.

TEST 3 – Switch = 3

- ◆ Connect CH 1 to TP3 (Blue).
- ◆ This should be a waveform similar to what you have seen before. Do your measurements including the rise time and the time constant.

This is another straight forward exercise. Measure everything, in particular, the rise time and the time constant. (Make sure you know the difference between the two.)

You should work out the mathematical formula governing this waveform shape.

TEST 4 – Switch = 4

- ◆ Connect both probes to TP4 (Yellow).
- ◆ Now set CH2 to x1 setting, and leave CH1 on x10.
- ◆ Measure the rise time for the two waveforms and explain your results.
- ◆ Now move the earth wire and cable of CH1 and observe how this affects the CH1 waveform.

This test is to refresh your memory on why we need to use a x10 scope probe to do measurements.

You will be measuring a fast digital signal using both scope probes, one on x1 setting and the other on x10 setting.

You should also see that measuring a fast signal is not easy. The probe itself actually causes some spurious effects on the measurements. Basically most fast digital signals are far from the ideal waveforms that you may see in textbooks. Real digital signals often show these spurious oscillations.

For digital signals, this is OK because digital logic uses threshold voltages to determine the logic values. Here we are using 3.3V logic thresholds. Any voltages below 0.8V are regarded as logical 0. Anything above 2V is regarded as logical 1. Therefore the oscillation and the transitional noise will be ignored by digital logic circuits.

Measure the rise time as measured by CH1 and CH2 probes.

The reason for the spurious oscillation is that the earth wire of the probe and the cable presents itself as an inductor (something that will be covered by Mike Brookes later). It is this inductance of the inductor interacting with capacitors and resistors that causes the oscillatory behaviour. As you move the wire around, the inductance is changed, hence you see the changes in the waveform on the x10 probe.

You don't see that on the x1 probe because its bandwidth is too low (poor) to show such high frequency effects.

TEST 5 – Switch = 5

- ◆ Connect CH 1 to TP3 (Blue).
- ◆ Explore and measure.

This is another interesting signal. It shows a sinewave with additional signal on top. Characterise this.

TEST 6 – Switch = 6

- ◆ Connect CH 1 to TP4 (Yellow) and CH2 to TP5 (Black).
- ◆ Trigger on CH1.
- ◆ Adjust the potentiometer knob (bottom left of PCB) and see the effects on both signals.
- ◆ Explore and measure the relationship between the duty cycle of the signal on CH1 and the mean value (DC voltage) on CH2. Plot the mean voltage on CH2 vs duty cycle of the signal on CH1.

CH1 shows a digital signal known as a pulse-width modulation signal. You can change the duty cycle of this signal by varying the potentiometer.

CH2 is the result of passing the CH1 signal through an averaging circuit (also known as a low-pass filter). The actual working of this averaging circuit is not relevant to this experiment. What it does is simply to produce a DC output which is the mean voltage of CH1.

You can use the digital volt meter (DVM) function of the scope to measure the DC voltage on channel 2.

To turn on DVM function for CH2:

1. Press UTIL button
2. Select on-screen menu, DIG VOLTMETER
3. For channel 2, select DC measurement. CH2 DC voltage will now be shown on the top left corner as shown.

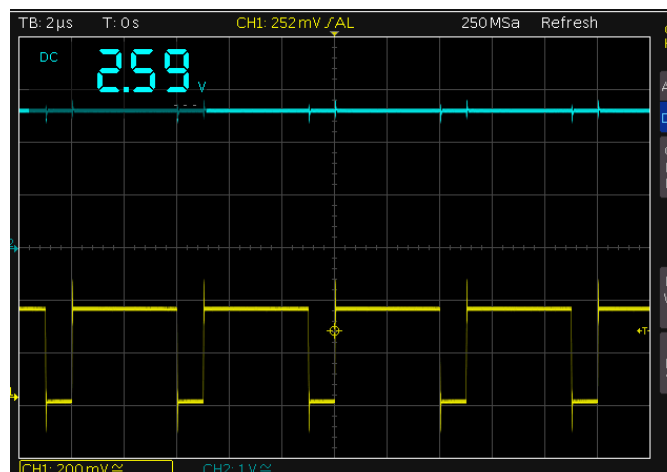

TEST 7 – Switch = 7

- ◆ Connect CH 1 to TP3 (Blue) and CH2 to TP4 (Yellow). Trigger on CH 2.
- ◆ This is a digital signal of a four letter word (e.g. "#SOS") in ASCII format. The first letter is always a '#'.
- ◆ This is related to Task 8 in part 1 of this experiment (lab 1 slide 19). The signal format is that of a UART.
- ◆ V_{TP3} is high during the time when the four characters are being sent. This provides the trigger for the scope.
- ◆ Discover the remaining THREE letters of this hash-tag. What is the repetition rate?
- ◆ You need to use a table of ASCII codes. This is provided below.
- ◆ If you find this difficult, you can find out what to expect first and then verify that you are seeing what you expected. To do so, run the self-test programme on the laboratory webpage.

This test is to see if you understand how a digital signal can be used to carry information. The signal on TP4 is a digital signal for repeatedly sending a four letter word such as "#SOS" (e.g. a hash-tag).

Your job is to discover the word being sent and at what repetition rate. The letters are coded in ASCII (**A**merican **S**tandard **C**ode for **I**nformation **I**nterchange). Here is the ASCII table:

Decimal	Hex	Char	Decimal	Hex	Char	Decimal	Hex	Char	Decimal	Hex	Char
0	0	[NULL]	32	20	[SPACE]	64	40	@	96	60	`
1	1	[START OF HEADING]	33	21	!	65	41	A	97	61	a
2	2	[START OF TEXT]	34	22	"	66	42	B	98	62	b
3	3	[END OF TEXT]	35	23	#	67	43	C	99	63	c
4	4	[END OF TRANSMISSION]	36	24	\$	68	44	D	100	64	d
5	5	[ENQUIRY]	37	25	%	69	45	E	101	65	e
6	6	[ACKNOWLEDGE]	38	26	&	70	46	F	102	66	f
7	7	[BELL]	39	27	'	71	47	G	103	67	g
8	8	[BACKSPACE]	40	28	(72	48	H	104	68	h
9	9	[HORIZONTAL TAB]	41	29)	73	49	I	105	69	i
10	A	[LINE FEED]	42	2A	*	74	4A	J	106	6A	j
11	B	[VERTICAL TAB]	43	2B	+	75	4B	K	107	6B	k
12	C	[FORM FEED]	44	2C	,	76	4C	L	108	6C	l
13	D	[CARRIAGE RETURN]	45	2D	-	77	4D	M	109	6D	m
14	E	[SHIFT OUT]	46	2E	.	78	4E	N	110	6E	n
15	F	[SHIFT IN]	47	2F	/	79	4F	O	111	6F	o
16	10	[DATA LINK ESCAPE]	48	30	0	80	50	P	112	70	p
17	11	[DEVICE CONTROL 1]	49	31	1	81	51	Q	113	71	q
18	12	[DEVICE CONTROL 2]	50	32	2	82	52	R	114	72	r
19	13	[DEVICE CONTROL 3]	51	33	3	83	53	S	115	73	s
20	14	[DEVICE CONTROL 4]	52	34	4	84	54	T	116	74	t
21	15	[NEGATIVE ACKNOWLEDGE]	53	35	5	85	55	U	117	75	u
22	16	[SYNCHRONOUS IDLE]	54	36	6	86	56	V	118	76	v
23	17	[ENG OF TRANS. BLOCK]	55	37	7	87	57	W	119	77	w
24	18	[CANCEL]	56	38	8	88	58	X	120	78	x
25	19	[END OF MEDIUM]	57	39	9	89	59	Y	121	79	y
26	1A	[SUBSTITUTE]	58	3A	:	90	5A	Z	122	7A	z
27	1B	[ESCAPE]	59	3B	;	91	5B	[123	7B	{
28	1C	[FILE SEPARATOR]	60	3C	<	92	5C	\	124	7C	
29	1D	[GROUP SEPARATOR]	61	3D	=	93	5D]	125	7D	}
30	1E	[RECORD SEPARATOR]	62	3E	>	94	5E	^	126	7E	~
31	1F	[UNIT SEPARATOR]	63	3F	?	95	5F	_	127	7F	[DEL]

TEST 8 – Switch = 8

- ◆ Connect CH 1 to TP3 (Blue) and CH2 to TP2 (Green). Trigger on CH 1.
- ◆ You will see two sine waves being displayed.
- ◆ Varying the potentiometer will change the phase relationship between the two signals.
- ◆ Your job is to find the range (i.e. minimum and maximum) phase difference between the two signals, using CH 1 signal as the reference.

This is the final signal you will be measuring for this experiment.

Both sine signals have an amplitude of around 326mV, a DC offset of about 1.65V and a frequency of about 10Hz.

Assuming that the signal on CH1 has the equation:

$$V_{CH1} = 0.326 \times \sin(2\pi f_s t) + 1.65$$

and that

$$V_{CH2} = 0.326 \times \sin(2\pi f_s t + \theta) + 1.65$$

You are required to find the maximum and minimum values of θ when the potentiometer is set at the two extreme values.

Completion and Feedback Interview

- ◆ Congratulations! You have completed your first experiment in your first year. Now go to the **experiment's webpage** and answer a short online questionnaire to tell me what you think about this experiment and to check that you have achieved your learning outcomes.
- ◆ Take your logbook to a member of Lab staff who will conduct a 15-minute **feedback interview** with you and have your logbook checked for effectiveness. He/she will provide you with feedback on what you have done and what you have understood by filling out the form below.
- ◆ The purpose of the interview is to help you to learn. It does not count towards your first year's overall grade.



Print your
name here

Experiment Feedback Form (To be completed after the feedback interview)

1. How well has the student mastered the use of the oscilloscope?

Completely

Very well

Competent

Need to improve

2. How well has the student understood the different types of electrical signals?

Completely

Very well

Competent

Need to improve

3. How well has the student been using the logbook to good effect?

Highly effective

Effective

Can improve

3. Can you find evidence of initiatives and self-learning with this student?

Plenty of evidence
of self-learning

Some evidence
of self-exploration

Just followed instructions

FEEDBACK COMMENTS: